

Safety measures for drilling and blasting operations

35.1 INTRODUCTION

In order to carry out drilling and blasting under safe conditions, the following aspects must be observed:

1. Comply with the Rules and Regulations that are in effect.
2. Proper technical instruction for the operators, masters and personnel who handle explosives.
3. Machinery, explosives, accessories and initiation systems must be used under safety conditions.

The drilling superintendent should supervise these three conditions as, if not, the risk of accident will increase owing to over confidence, distractions, lack of knowledge and non-compliance with the safety rules, etc.

In this chapter, a general guide of basic recommendations is given which obviously should be complemented with the existing legislation.

35.2 BLASTHOLE DRILLING

35.2.1 General safety measures for blasthole drilling

The operation of drilling implies following a series of safety measures in order to minimize potential hazards to people as well as to material objects.

Drilling will be carried out according to the existing rules or policies, either official or those set by the company.

The operators should have received proper training and have studied the instruction book for the machine or machines which they are to handle, Fig. 35.1.

The members of the drill crew should be given garments which provide adequate protection (helmets, boots, gloves, glasses, masks, etc.), and use clothing and accessories that are not loose so as to avoid their catching on the moving parts of the machine.

The personal protection objects and those for the machine should be in good condition; if not, do not commence drilling.

The protection systems for the machine should not be disconnected, in order to avoid damage to itself or to people.

The starting and maneuvering controls should be protected so as to avoid manipulation by other people, which could constitute a risk.

The compressor on the rig should be equipped with a

fire extinguisher and a first aid kit, which the operators must know how to use.

If the work conditions are poor or dangerous, the equipment should not be used.

Place warnings on the control panel to advise of these conditions.

There should be signs that are well visible advocating the necessity of personal protection, Fig. 35.2.

35.2.2 Safety precautions before starting equipment

The crew members should be prepared to assume possible risks and have the means to confront them, as well as knowing where to look for help.

The driller should check the whole rig, even if everything was working correctly in the previous shift.

The drill crew should inspect the premises where they are going to work, its potential limitations, as well as the accesses to the area.

The pressurized hoses will be securely anchored, especially the main hose, which should have an additional safety cable at the connection point.

The threads and connection elements must be correctly tightened.

Check all fluid levels, oiling points and cleanliness of the machine according to the manufacturer's instructions, and make certain that all tools and equipment are in proper places and in good condition.

Possible fuel and other fluid losses must be watched, and the deposits will be purged according to the service instructions.

35.2.3 Safety measures during starting

When starting the machine, the following precautions should be observed:

- Make certain that unnecessary personnel are not on the rig or in the surroundings.
- Check to see that all controls are in the correct position.
- Inspect any possible warning signs or instructions on the rig.
- Start the drill by authorized operator, from the proper position and in the open air or with good ventilation.
- Never leave the rig when it is running.

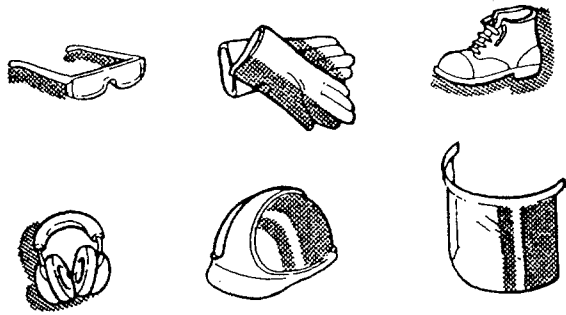

Fig. 35.1. Safety garments for personal safety.

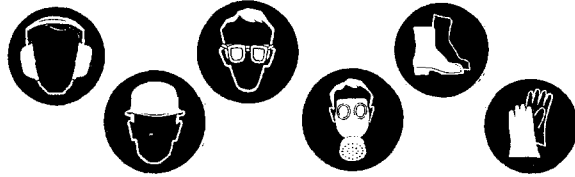

Fig. 35.2. Signs that warn of the obligation to use safety material.

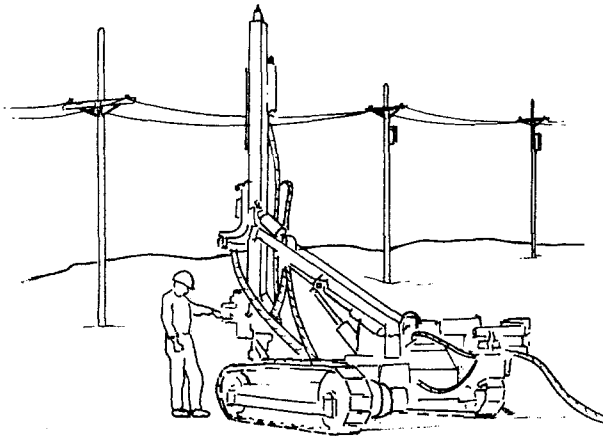

Fig. 35.3. Danger of contact with power lines.

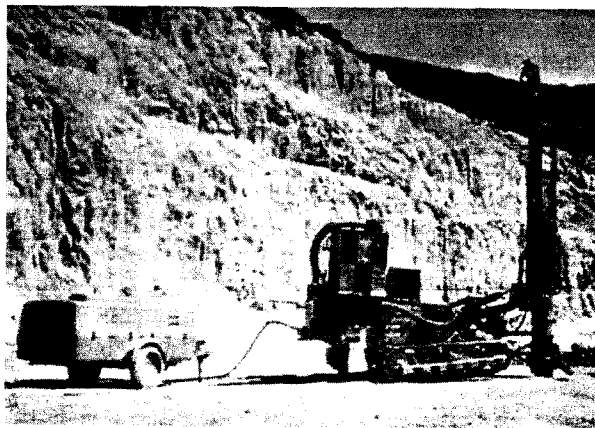

Photo 35.1. Drill equipment with compressor.

35.2.4 Safety measures after starting

Check proper functioning of all controls. Pay attention to any unusual noises.

35.2.5 Safety measures for surface movements of the rig

Before moving the equipment, the following should be checked out:

Make certain that the ground is in good condition for safe moving. If not, it must be prepared with the available auxiliary equipment such as tractors, shovels, etc.

The existence of elevated, surface or underground power lines. The rig must be kept at a minimum safety distance of 10 m from any electrical line, Fig. 35.3.

See if there are any underground pipelines, for gas or water, or telephone lines, in the way.

Stability of the slopes near the work area.

Slopes of the cuts where the rig is working. If necessary, the machines can be tied with cables and wenches.

The drilling accessories, especially drill pipes, must be immobilized.

The feed or drill mast must be put down when moving, 35.4.

When moving, the operator occupies the driver's seat designated by the manufacturer. No other person will be authorized on the rig or between the compressor and rig when it is being towed, 35.5.

The rig will not move over previously drilled areas.

The slopes encountered during movement must be within the limitations set by the manufacturer.

When the translation chains, hammer advance chain and drill pipe chain are in movement, the operators should remain at a safe distance.

When working with auxiliary electric equipment, a helper is needed for maneuvering between blastholes. He must control the cables, avoid passing over drilled holes, help direct the machine so that it won't go near the edges of the slopes and make certain that the hydraulic jacks are out of the way.

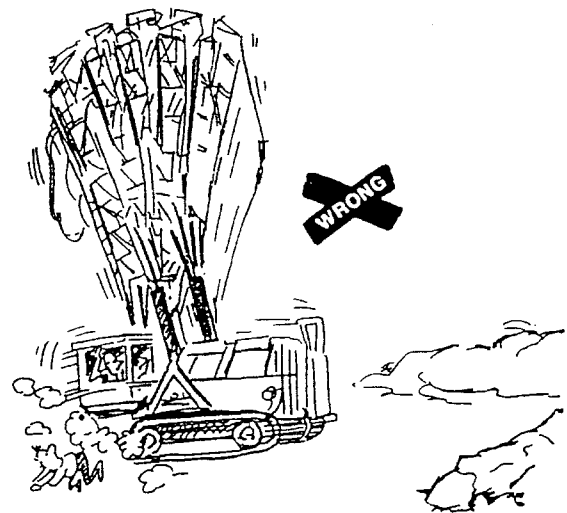

Fig. 35.4. Incorrect position of the mast when in movement.

2.6 Safety measures when working underground

sure that the roof of the drift is in good condition and, if necessary, take steps to make it safe, apart from using protective cabins on the rig, Fig. 35.6.

Make certain that there is sufficient ventilation for work at the far end of the drift, considering that each worker requires 40 liters per second and 180 liters per second when working with diesel equipment.

The floor over which the traffic will flow must be cleaned of debris and other materials.

Check the electric lines, compressed air and water lines, and make certain that they are properly anchored to walls in access ways.

The work area must be properly illuminated.

Grounding must be available, combined with cut-off switches and alarms in the electric machinery.

The waste water drains must be kept clean and all water removed from the work zone.

All necessary work utensils must be kept in order and in their proper place.

The bottom of the blastholes that are unserviceable must be visibly indicated and no other hole drilled within a distance of 20 cm. Never use blasthole bottoms as collar points.

2.7 Safety precautions during drilling

When the rig is being placed, the ground irregularities or instability must be taken into account, or the presence of underground work or pipelines. Make certain that the necessary rock mass for protection exists in accordance with the static and dynamic characteristics of the machine, Fig. 35.7.

In steep ground, when working with portable compressors they must be kept in a safe place.

Once the rig has been leveled and immobilized, the mast or drill tower can be positioned, slowly and paying attention to any obstruction that could exist.

Any maneuver that is potentially unsafe will require the aid of a helper who should be in visual contact with the operator.

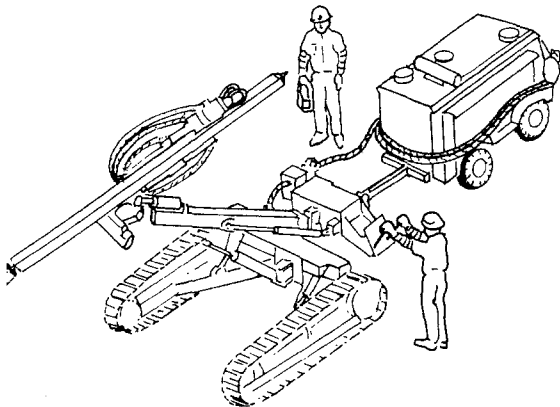

Fig. 35.5. Proper position of the operators during transport of the rigs.

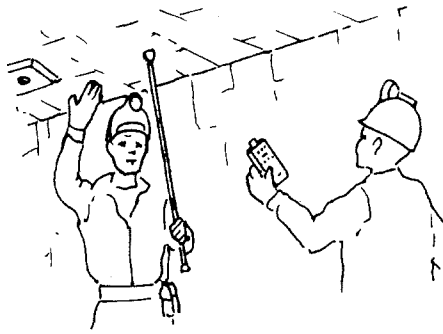

Fig. 35.6. Checking wall and roof conditions.

The drilling site should have appropriate conditions of visibility, as much for the operators as for other crew members.

Never collar upon bottoms of old blastholes. Don't use the lifting and lowering mechanisms of the rock drill for any other purpose than intended.

In the machines that have automatic rod or drill pipe changers, the operator should frequently check the mechanisms that make the drilling accessories run and stop.

When changing the drill pipes, attention should be paid to the drilling accessories (shanks, coupling sleeves, etc.) which could be poorly connected.

The drilling accessories must always be in good condition. The pieces which appear worn could affect the safety of the operation and should be thrown away.

The drilling accessories should be stored in adequate places, protected from dust and blows. Never hit metal against metal without eye protection, Fig. 35.8.

During drilling, the machine must have all its control levers, protections and guard plates in perfect condition.

When drilling, write down the numbers indicated on the controls and also note in the report any incidents which might arise.

The crew members should never go under the rotary drills when the jacks are lifted, unless fixed stops have been placed.

When a drill pipe is taken out of the carousel, make certain that it is correctly directed.

When drilling blastholes, check the descent of the rotary head or percussion hammer.

Operators should always remain away from moving parts of the drill, such as hammer chainfeeds, cables, belts, compressor, etc., and the levers must be operated from correct positions.

The drill steel, couplings, bits, etc., that have just been used should not be touched with bare hands as there is risk of burns.

When heavy accessories are lifted or handled, the following precautions should be taken:

Keep legs open, placing a foot on each side of the object. Bend the knees and squat down, keeping the head erect. Grab the object with the whole hand, embracing it with the arms. Keep weight on both feet, lifting the object with the back muscles of the legs, Fig. 35.9.

When placing the object, don't turn the body and keep it close to where the object is to be deposited.

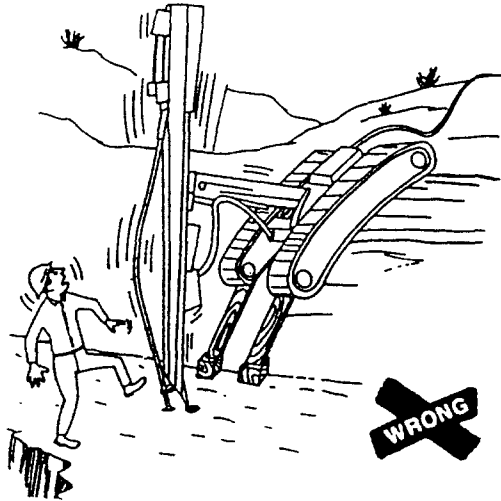

Fig. 35.7. Never work with the equipment when it is unstable or in a precarious position.

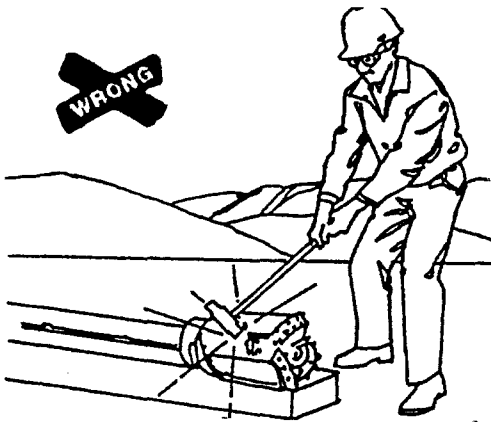

Fig. 35.8. Never strike metal objects against each other without eye protection.

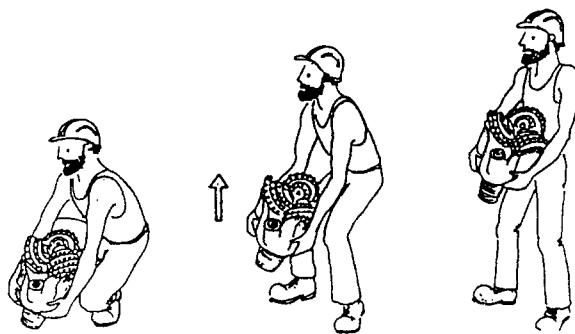

Fig. 35.9. Every precaution should be taken when lifting heavy objects.

35.2.8 Safety measures after drilling

Never leave the machine with the motor still running.

The procedure to stop the machine should be carried out according to the manufacturer's instructions.

Never park the machine in areas that could become flooded, or where it could be reached by flyrock, Fig. 35.10.

If there is any circumstance that could affect the use of the rig, a warning note should be left on the ignition controls before leaving the machine.

Try to avoid parking on a slope. If necessary, use the prescribed braking apparatus and place proper wedging.

Before leaving the rig, release pressure from all circuits, leave controls on off and park positions, using the existing brakes and taking away the keys, if they exist.

35.2.9 Safety precautions in maintenance and service

The personnel which is to handle the maintenance, repair and service operations will be designated by the Company.

The service instructions specified by the manufacturer in its Service and Maintenance Manual will be strictly followed at all times.

During maintenance and repair, the rock drill must be perfectly braked and immobilized so that it can not move unexpectedly.

The starting controls should be blocked and marked so that only authorized persons can use them.

Any operations that imply movement of the drill feed or mast must be carried out with the driller in the control cabin, and any other person nearby must place himself behind the machine.

Servicing of the motor compressor batteries implies potential risks of burning by the sulphuric acid, and fires and/or explosions, as they produce hydrogen and oxygen.

The personnel attending to the batteries must always wear safety glasses, gloves and clothing that is acid resistant, Fig. 35.11.

When changing a battery, the ground terminal will be the first to be disconnected and the last to be connected.

The electrolyte level should be checked frequently and when necessary add distilled water, always before starting the motor, never after stopping. A correct level means lower volume of gases inside the battery.

Never use a flame to check the level of a battery, always use a flashlight or portable lamp.

When charging the batteries, leave the caps off the deposits. The terminals from the charging apparatus should be applied and removed with the switch turned off.

Never smoke near batteries or when working with them.

No crew member is allowed to climb up the drill tower unless it is a case of extreme necessity. If this case arises, a safety belt that is attached to the tower must be worn.

Hands, arms and the rest of the body, as well as work clothes, must be kept away from any moving part of the rock drill or compressor (chains, pulleys, drill, etc.).

Do not open any deposit, water or oil hose when the rig working, or if they are pressurized.

Check the state of the safety valves at least once a week. They should be in perfect working condition.

Never repair safety valves of the pressurized circuits. Always replace with new ones.

Never go above the pressure recommended by the manufacturer for any pressurized equipment.

Do not use air hoses with pressures over 0.2 MPa for cleaning filters, work clothes, dust, etc. When necessary, use protective glasses, Fig. 35.12.

Refuelling must be carried out with the motors off and in perfectly ventilated areas.

Avoid spilling fuel on surfaces that are at higher than environmental temperatures. The refuelling hoses should have appropriate nozzles.

When fuel is spilled, before starting the engine clean all affected surfaces.

Smoking is forbidden in a radius of at least 10 m from the refuelling point, as well as any flames, incandescent materials or anything that can produce sparks, Fig. 35.13.

Have fire extinguishers available at the refuelling point for type B fires (grease, gasoline, dissolvents, paint, etc.).

Avoid completely filling the fuel tanks as their volume can vary with the temperature.

When checking the level of the cooling liquid in the motor compressor, the engine must be off and the radiator at environmental temperature.

35.3 BLASTINGS

Before indicating the recommendations for the different stages of blasting, it must be stated that, except in underwater blasts, *it is expressly forbidden to charge blast-holes during drilling*. There could be accidental detonation through contact with the drilling tools and equipment.

35.3.1 Measures to be taken when storing explosives

Always store explosives in powder magazines that fulfill the acting rules and regulations.



Photo 35.2. Surface powder magazine with natural protection.

Make certain that the magazine is clean, dry, well ventilated, reasonably cool, of solid construction, fire resistant, and securely locked.

Always use or give out the oldest products first or, which is the same, in the order that they entered the magazine.

Store the products of the same type and class in such a manner that their identification is simple. This entails their revision and age control.

Take special precautions with defective boxes or broken wrappings. Place them in a separate area of the magazine.

Place the magazines in isolated and strategic locations, in accordance with the distances set by the regulations in force.

Consult with the manufacturer as to cleaning procedures when any liquid substance of deteriorated explosives has spilled on the magazine floor.

If artificial illumination is necessary, use safety lamps.

Immediately repair any leaks that might appear from walls or roof.

Never open or rewrap the boxes of explosives inside the magazine.

Do not leave loose explosives or open boxes inside the magazine.

Never store blasting caps or other initiation accessories in the same magazine.

Do not store detonating cord in the same place as the electric blasting caps.

Do not store metal objects that could produce sparks in the magazine.

Never store oils, gasolines or dissolvents in the same area.

Matches or lighters are strictly forbidden inside or near the magazine.

Place clearly visible warning signs around the installations and when transporting explosives, Fig. 35.14.

35.3.2 Precautions when transporting explosives inside the working area

Strictly obey the conditions established by the Regulations in force.

Make certain that any vehicle assigned to the transport of explosives complies with the stipulated regulations.

Check the running condition of the vehicle to see if everything is in good order. Do not allow the load to stick out and have canvas on hand to cover the explosives if it rains.

Carry fire extinguishers on the vehicles, properly placed and in easy access. The knowledge of their use is obligatory for drivers and helpers.

The engine of the vehicle must always be turned off when loading and unloading explosives.

Check the floor of the vehicle to be certain that there are no cracks or holes.

Always load and unload the vehicles during daylight hours and never when there are electric, sand or snow storms.

When loading and unloading explosives, only autho-



Photo 35.3. Flexible measuring tape to control charge height and blasthole depth.

rized personnel are allowed to remain in the area, prohibiting any other activity within a radius of 50 m.

Never transport metal, fuel or corrosive materials with explosives.

Smoking is strictly forbidden for anyone in or near the vehicle.

Do not allow the boxes of explosives to be opened when still in the vehicle or in the unloading area until this operation is finished.

Never transport blasting accessories with explosives. Detonating cord is considered an industrial explosive.

Always transport the explosives in their original wrappings and boxes, or in specially prepared cartons.

Name a person to be responsible for the movement and dispatch of explosives and blasting accessories.

When unloading, explosives, blasting caps, detonating fuses, etc. should be handled with extreme care and never be dropped or receive blows, Fig. 35.15.

Distribute the explosives to be used in the blast in order to avoid leaving large amounts piled up.

Always use routes with the least traffic of personnel, as well as of other machinery.

Place the blasting caps far away from the charging zone.

Supervise unloading of explosives until they are placed in the blastholes and the round connected.

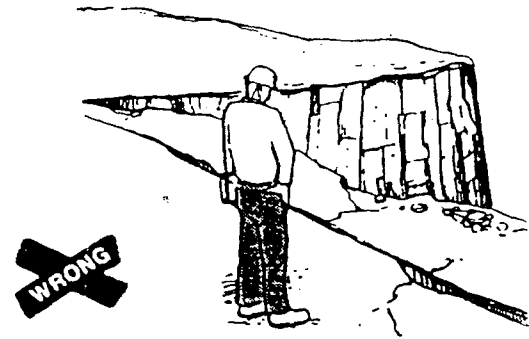

Fig. 35.10. Avoid parking rigs near the walls.

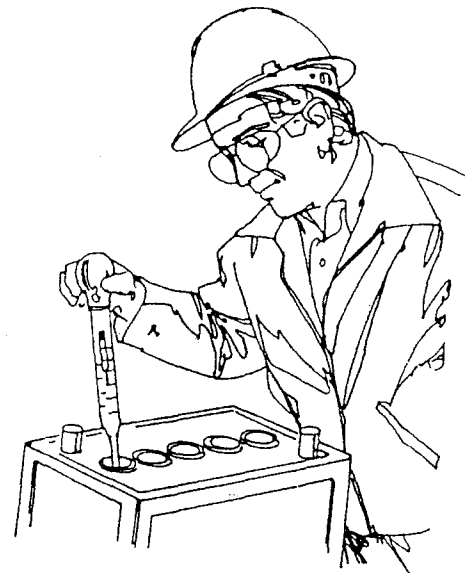

Fig. 35.11. When handling batteries, all pertinent precautions must be taken.

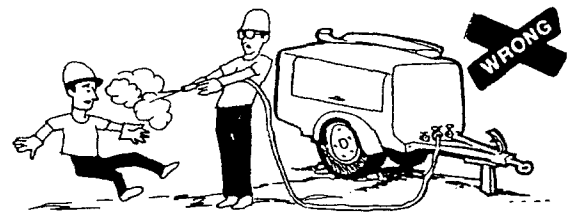

Fig. 35.12. Never use compressed air to clean work clothes.

35.3.3 Precautions in the blasting area

Clean the blast area, removing loose rocks, bushes, metals and other materials.

Mark the blasting area limits with sticks or brightly colored flags and prevent the passing of any machinery over it, Fig. 35.16.

When changing shifts, inform the operation personnel of the blasts to be carried out that day.

Prevent access of anyone not directly involved with the handling of explosives to the marked zone and its proximities.

Reduce the number of charging crew members to a minimum and name a person to be in charge and a supervisor.

Correctly mark the location of all blastholes.

35.3.4 Measures to be taken when preparing the primer cartridge

Prepare the primers according to the methods recommended by the manufacturers of explosives and check that the initiator is well placed inside the cartridge.

Be certain that during charging there is no tension in the detonator cables or in the detonating cord and in the joints of union.

Insert the detonators inside a hole made in the primer cartridges with a special tool called a pricker, which can be of wood, copper, bronze or any metal alloy that does not produce sparks.

The primers should not be prepared much in advance nor in greater quantity than what is to be used immediately. This operation should not be carried out in the magazine nor near explosives.

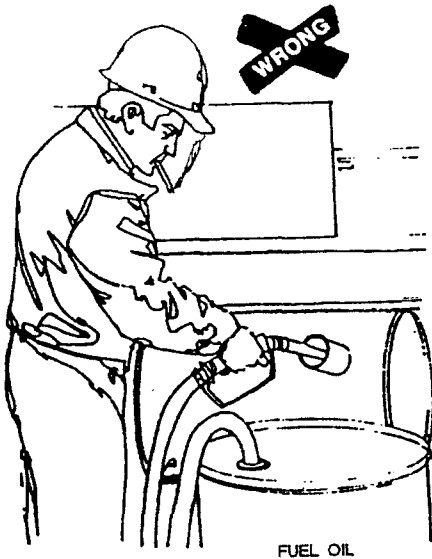

Fig. 35.13. Smoking is forbidden during refuelling.



Fig. 35.14. Warning sign for explosives.

35.3.5 Precautions when charging blastholes

Examine each blasthole carefully before charging to know its length and condition, using a wooden rod, a scraper or even a measuring tape, Photo 35.3.

Always foresee the possibility of danger from static electricity when using an pneumatic charger and take all necessary precautions such as connecting a ground line. Remember that relatively low humidity in the atmosphere increases the risk of static electricity.

Cut the necessary detonating cord from the reel once it has been inserted in the blasthole and before inserting the rest of the explosive charge, Fig. 35.17.

Prevent the personnel dedicated to charging from exposing part of their body over the blasthole that is being charged or from placing themselves in its same direction.

Wrap the end of the detonating cord around a wooden stick or rock to keep it from falling inside the blastholes, Fig. 35.18 and Photo 35.4.

Waterproof the ends of the cord in blastholes with water.

Check the rising of the bulk explosives and take the necessary precautions in case of holes or cavities in the blastholes which could have been detected during drilling or even when charging, Fig. 35.19.

Never leave surplus explosive in the work area during and after charging the holes.

Do not charge the holes right after drilling without first checking to see if they are clean and free of metal pieces or leftover hot accessories.

Do not deform, mistreat or let the primer drop into the blastholes. Never let any heavy weight fall on them, Fig. 35.20.

Never recharge holes that have already been charged and fired before.

35.3.6 Precautions when tamping

Confine the explosives in the holes with sand, earth, or any other appropriate incombustible material.

Do not use any type of metal tamping tools. Always use wooden tools or others of adequate material, without metal parts except for the special connectors in articulated tamping rods that are made of a metal that does not give off sparks, Photo 35.5.

Stem with care so as not to harm the initiating accessories, detonating cord, etc., and make certain that they have no knots or kinks.

Never directly tamp the primer cartridges.



Photo 35.4. Fastening the detonating cord during charging.

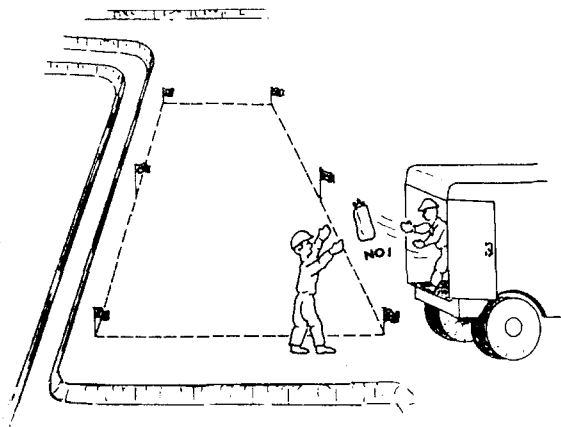

Fig. 35.15. Unloading explosives and blasting accessories should be carried out with great caution to avoid blows.

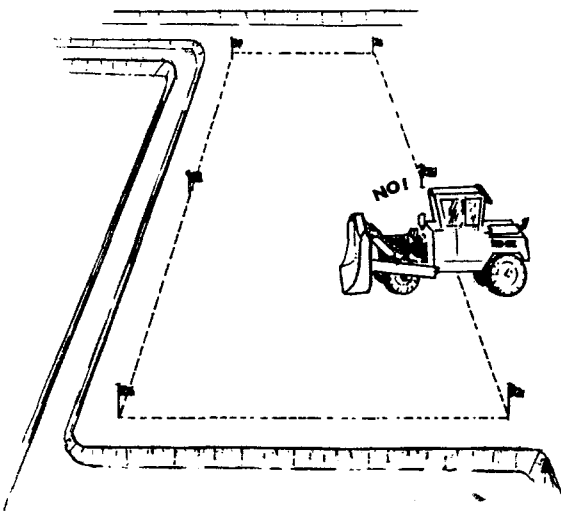

Fig. 35.16. Prevent the passing of machinery over the area of the blast from the moment the preparations are started.

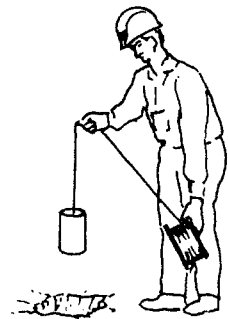

Fig. 35.17. Introduction of the primer with detonating cord in the blastholes.

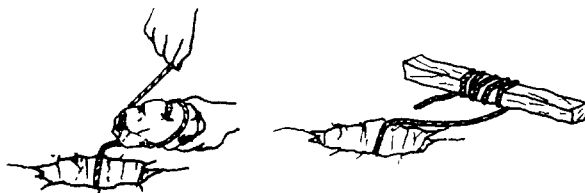

Fig. 35.18. Wrapping of the end of the detonating cord to keep it from falling inside the hole.

Make certain that the stemming material contains no rocks or other objects.

In blastholes with presence of water make certain that the stemmings have not descended before connecting the circuits. If so, correct them.

35.3.7 Measures to be taken when blasting with electric blasting caps

Keep the electric blasting cap wires or conductors short circuited and never connect one cap to another until ready to fire.

Check all the blasting caps, one by one or connected in series with the proper blasting ohmmeter designed for this purpose. If checked individually, place yourself in a safe area and introduce the cap in a protective tube, Fig. 35.22.

Never throw the wires in the air to straighten them nor tense them.

Never unroll the leg wires or use the electric caps during a storm or near any source of static electricity or unusual currents.

Never use the caps nor unroll their leg wires near radio transmitters or television stations, electric lines, etc., unless at a safe distance and complying with the regulations in force.

Do not place cables or electric lines near the blasting caps, nor any other explosive until the moment of firing the shot and only for this purpose.



Photo 35.5. Tamping blastholes.

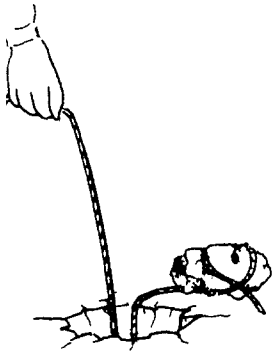

g. 35.19. Check the rising level of the explosive when charging.

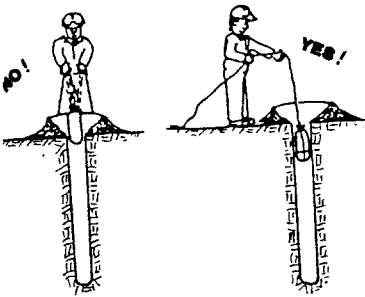

g. 35.20. Never let the primer cartridge drop into the blastholes.

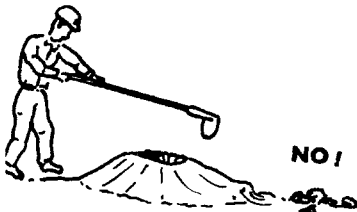

ig. 35.21. Avoid rocks in the stemming material.

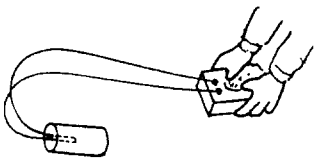

Fig. 35.22. Checking electric blasting caps.

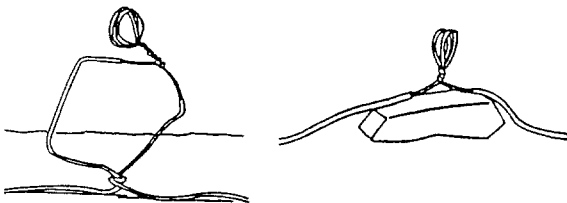

Fig. 35.23. Isolate the connections from the ground.

Take away all surplus explosive from the shot area before the placing or connecting of the caps by the shotfirers.

Push a copper rod into the ground close to the shot before any connecting is done. This is for the discharge of static electricity that could be on the personnel who handle the caps.

Prevent the passing of machinery and the laying out of cables that provide power for them anywhere near the shot area.

Check to make certain that the ends of the leg wires are absolutely clean before making any electric connection.

Carry out the connections as quickly as possible and in one operation, preparing in advance all necessary items.

Once the connection has been done, protect the ends of the wires by completely isolating them so as to avoid any contact with the ground, Fig. 35.23.

Never use blasting caps of different sensitivities on the same circuit.

Avoid proximity of the firing line to other power lines, as well as contact with metal elements, Fig. 35.24.

Before connecting, check the isolation of the firing line and the uniting points of the blasting caps. Use quick connectors for the latter when necessary.

Do not connect the firing line to the blasting machine until ready to fire the blast and keep it short circuited.

Never try to fire a blast with a higher number of caps than recommended by the manufacturer of the blasting machine.

Check and revise the blasting machine periodically as well as the checking equipment.

In the case of cap misfire, never try to open or dismantle it.

35.3.8 Precautions to take when firing with fuse detonators and safety fuse initiation

Blast as little as possible with fuses and reduce the number of blasthole in each round.

Handle the fuse with care to avoid damaging the covering.

Light the fuse with a fuse lighter designed for this purpose.

Always work with fuses of more than a meter and a half in length. The burning time must be known and make certain that there is time to reach a safe place after lighting. A test fuse can be used for this information.

Cut the fuse when ready to insert it into the fuse detonator. Cut an inch or two off to insure a dry end.

Cut the fuse squarely across with a fuse cutter designed for this purpose and insert it gently against the powder charge of the detonator. Once placed, avoid twisting it.

Crimp the end of the fuse detonator with a cap crimper where the fuse enters. Make certain that the detonator is securely crimped to the fuse to avoid its breaking loose or getting wet.

Never light the safety fuse without covering the explosive sufficiently to prevent sparks from coming into contact with it.

Never have explosives in your hand when lighting the safety fuse.

Before returning to the cut, count the number of holes that have exploded and wait a half hour if there has been a misfire.

35.3.9 Safety measures before and after the blast

Make certain that all surplus explosives are in a safe place and that all persons and vehicles are at a safe distance and well protected.

Prevent access to the blast area with adequate personnel and means, Fig. 35.25.

Never fire the shot without a signal of authorization from the person in charge and without having given adequate warning.

Shoot from safe places such as behind protective blasting shelters, loader shovels, etc.

Never go back to the blast area until all smoke and gases have dissipated.

Do not investigate a misfire too soon. Follow the regulations and local laws set for this purpose or, if none are available, wait a prudent time.

In case of misfire, do not drill or otherwise handle an explosive charge without instructions from a competent and experienced person and who expressly is authorized to solve this type of problem.

Organize all work so that the blasts coincide with the moments when least personnel is present, and try to always use the same time of day.

35.3.10 Safety precautions with misfires

Place warning signs on misfired blastholes.

The situation must be corrected before recommencing drilling in proximate areas.

If the round was electric and the circuit is visible, check to see if it is continuous from a safe distance and fire it if all is correct, take extra precautions for possible flyrock.

In case of priming with detonating cord, try to remove the stemming material and place a primer cartridge next to the explosive for its destruction. Stem the round with sand or a fine granular material.

If the explosive cannot be reached, drill a new hole at a

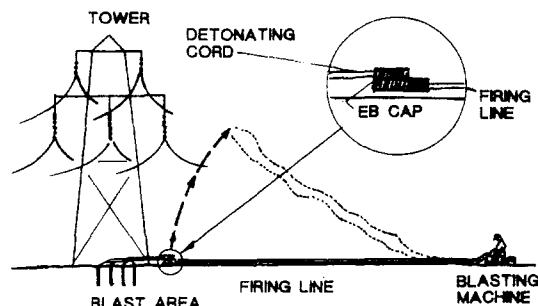

Fig. 35.24. Recommended initiation system when firing blasts in areas that are very close to power lines.

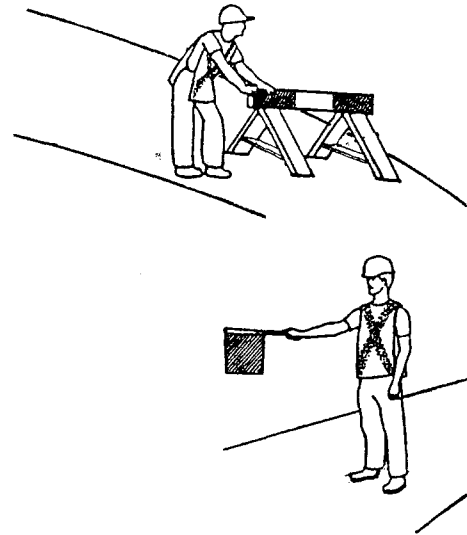

Fig. 35.25. Control all accesses to the blast area.

distance of over $10 D$, when the local laws and regulations in force permit.

Always use highly specialized personnel for the task of neutralizing and eliminating explosives that have not detonated.

35.3.11 Safety measures with secondary blasting

Check to see if cracks or fissures are visible on the surface of the boulders.

Place the boulders in an area where there is a shielding effect against airblast; for example, at the bottom of a stable wall.

Always try to use the blasthole method because the system of patch explosives or plaster shooting produce higher levels of airblast and noise.

35.3.12 Measures to be taken when discarding explosives

You should be aware that deteriorated or damaged explosives may be more dangerous than those in good condition.

Always destroy or discard explosives in compliance with the approved methods: by combustion, explosion and by chemical destruction. Maintain the prescribed distance.

When destroying by explosion, it is recommended that this be done inside a blasthole, under sand or water, because if it is carried out in the open the airblast and noise would be extremely high. Initiation should be electric with proper primers.

When combustion is used, the amount of explosive per round should not go over 15 kg. To the contrary, it should be carried out in various locations.

Never burn explosives in their original packing bags or boxes. Once extended over a surface, they can be sprayed with gasoline to favor combustion.

When various combustion operations are carried out, each one should be done in a different location.

Never allow paper, carton or other materials used to pack explosives to be burned in fireplaces, heaters or other closed places, nor used for other purposes. Place them in thin layers in an appropriate area and in the open air, and when burning, a distance of at least 30 m must be kept.

The chemical destruction, which is one of the methods used for blasting agents, especially ANFO, is carried out by dissolving the nitrates in water. In these cases, precautions must be taken to control contamination.

When discarding detonating cord, the best procedure consists of laying it out in straight lines in a bed of dry firewood or straw, wetting it with gasoline or fuel oil, as with conventional explosives. It should never be burned on the ground.

The electric detonators and milisecond delay caps are destroyed, if in large quantities, confined in a cavity or hole in the ground with the help of some explosive or by wrapping detonating cord several times around the bunch of accessories.

REFERENCES

- Anonimo: *Normas y Sistemas de Seguridad en los Túneles*. Noticias Perfosa, no 2, Revista Minera, Febrero, 1987.
- Atlas Powder CO.: *Electrical Hook-Ups Surface Blasting*.
- B.O.E.: *Instrucciones Técnicas Complementarias*. 11 de Abril de 1986.
- Encasur: *Medidas de Seguridad. Perforación y Voladura*. 1982.
- Estudios y Proyectos Mineros: *Manual de Seguridad en Minería a Cielo Abierto*. ITGE, 1991.
- EXSA: *Siempre-Nunca lo que Vd. Debe Saber al Usar Explosivos*. Perú, 1985.
- Gadner-Denver: *Drilling with your Gardner-Denver Rotary Rig*.
- Ingersoll-Rand: *Safety Manual*.
- Langa, E.: *Precauciones en la Perforación y Carga de Explosivos*. Normas de Seguridad en el Uso y Manejo de Explosivos. INSHT, Octubre, 1984.
- Pavetto, C.S.: *Surface mine blasting - A program guide for certification*. McGraw Hill, Inc., 1986.
- Union Española de Explosivos, S.A.: *Transporte de Explosivos por Carretera*.
- Union Española de Explosivos, S.A.: *Prescripciones que se han de Poner en Práctica en los Supuestos de Rotura o Deterioro de Envases y Embalajes*.
- Union Española de Explosivos, S.A.: *Dstrucción de Explosivos Industriales*.