

# Tests on explosives

---

### 21.1 INTRODUCTION

All explosives are extremely dangerous. Even one kilogram of many explosives is sufficient to kill hundreds of persons. To ensure that no disaster happens, Governments of most countries lay down very stringent requirements about various aspects related to the properties of explosives. Manufacturers of explosives, in turn, have to carry out many tests on their products to ensure that the characteristics of explosives are within the limits permitted by the governing authorities.

This chapter is devoted to giving details of many tests usually identified as essential to resolve many issues related to the hazards analysis of existing or proposed facilities, process, or products.

There are literally hundreds of tests meant to measure the properties of explosives. Only a few important ones have been briefly described here.

### 21.2 TESTS FOR MEASUREMENTS OF VOD

VOD is the acronym of Velocity of Detonation. Velocity of detonation is measured by using many different techniques. Tests commonly used for laboratory measurement of velocity of detonation are:

- 1 D'Autriche method
- 2 Chronograph method

Velocity of detonation measured in the laboratory differs significantly from the one experienced in a blasthole. Measurements of velocity of detonation in a blasthole are carried out by the following methods.

- A Fiber optic sensor method
- B SLIFER method
- C Optical measurement method
- D CORRTEX method

A brief overview of all these methods is as under.

### 21.2.1 D'Aurriche method

Actually this method compares the velocity of an explosive with that of a detonating cord that has a known velocity of detonation. From the result the detonation velocity of the explosive can be found precisely.

This test is carried out in a laboratory.

In actual tests a detonating cord having a precisely known velocity of detonation is inserted in a tube loaded with explosive to be tested at points A and B as illustrated in Figure 21.1. Midpoint C of the cord length is kept on a lead plate and its position on the plate is marked. When the explosive tube is detonated from one end and the detonation zone reaches point A, the cord also gets detonated. A detonation wave in the cord starts traveling towards the other end.

After some time interval the detonation zone in the explosive tube travels a distance  $d$  and reaches point B. Here the other end of the detonation cord is also ignited. A detonation wave in this end of the cord also starts traveling towards the first end.

Since the plate is of lead, which has high malleability and low melting point, a mark is easily visible at the point D where the two detonation zones in the cord meet.

By precise measurements of the distances  $d$ ,  $k$ , and length AC and the velocity of detonation in the cord, the velocity of detonation in the explosive tube can be calculated by using the following equation.

$$V_e = V_c * d / (2 * k)$$

where

$V_e$  = Detonation velocity of explosive (m/s)

$V_c$  = Detonation velocity of cord (m/s)

$d$  = Length of explosive between two ends of the cord (m)

$k$  = Distance between point of collision of detonation in cord and midpoint of cord (m)

### 21.2.2 Chronograph method

In this test, carried out in a laboratory, two electric probes, that detect detonation and which send a signal through a wire attached to them, are placed at a certain distance  $d$

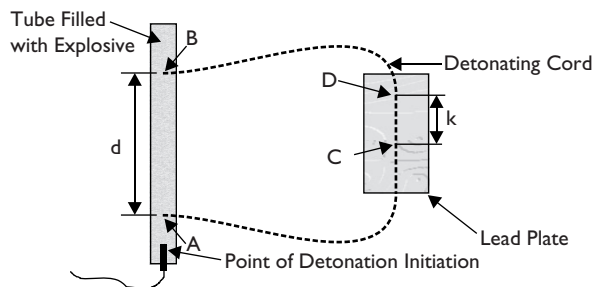

Figure 21.1 D'Aurriche method of detonation velocity measurement.

in an explosive-filled tube. The other ends of the probe wires are connected to a special instrument, called a chronograph. A chronograph measures the time interval between two signals sent to it to an accuracy of one microsecond. This way the time interval  $t$ , for the travel of the detonation zone over a distance  $d$  is known. Most such instruments are able to directly calculate and show the velocity of detonation when the value of  $d$  in terms of appropriate units is fed through an input device. In modern instruments, fibre optic cables are used for better accuracy. These cables transmit the signals in the form of light rather than electric current.

### 21.2.3 Fiber optic sensor method

In this method a specialized fiber optic cable of 1 mm diameter with smaller holes drilled across it at specific uniform distances, is used. This cable is placed in the column of the explosive to be tested.

When the explosive is detonated and the detonation reaches the hole the air confined in the hole is compressed and ionized. This generates a light pulse in the cable. The timing recorded for the first pulse is 0.000. Later as the detonation zone travels in the explosive column, the light pulsed generated by second and third and subsequent holes are sent to the recorder where their arrival timings are measured. Since the uniform distance,  $d$ , between two consecutive holes is known, the velocity of detonation can be calculated from the recorded timings.

### 21.2.4 SLIFER method

SLIFER is an acronym of Shortened Location Indication by Frequency of Electrical Resonance. In this case a standard coaxial cable RG6U with a resistance of 75 ohm is placed centrally in the column of explosive in a blasthole. This cable forms the part of an oscillator circuit where the frequency measured by the instrument is dependent upon the length of the coaxial cable. When the detonation zone in the blasthole Advances, the cable burns and the effective length of the cable reduces. With this, there is an increase in the frequency measured by the instrument. As there is a well-defined relation between length of the cable and the frequency, the continuous measurement of frequency and time gives velocity of detonation in the blasthole. Instruments capable of giving a graphical display of velocity of detonation as shown in [Figure 21.2](#) are available.

Since the measurements of frequency are taken continuously the instrument can also display the instantaneous velocity of detonation throughout the explosive column in the blasthole.

Currently this method of measurement of velocity of detonation is most widely used in surface mining practice.

### 21.2.5 Optical measurement method

This method is mainly used for measuring the speed at which a shock wave travels through a shock tube and the time taken from initiation of the shock tube to detonation of the blasting cap at the end of the shock tube.

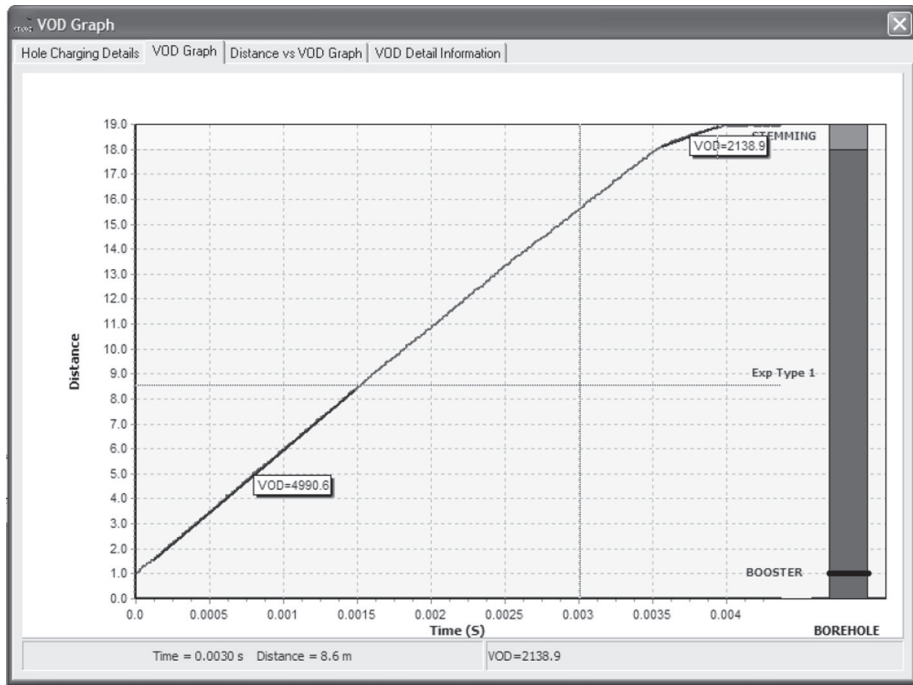

Figure 21.2 Graphical display of velocity of detonation.

A shock tube is a 3 mm diameter plastic tube lined with a coating of explosive powder. It is used as an accessory in blasting.

The nanosecond light pulse generated, when the explosive in the shock tube detonates, is used for starting the timer in the measuring instrument. When the detonator at the other end of the shock tube explodes the wire wound around it breaks and the timer stops. The reading of the time recorded can be used for calculation of the speed of shock wave travel and time for initiation of the blasting cap.

Apart from the above, some more techniques, such as CORTEX, are also used to measure the velocity of detonation of an explosive.

### 21.3 TESTS FOR MEASUREMENT OF STRENGTH

Several tests have been used in the past for evaluation of the strength of an explosive. In these tests a parameter related to the strength of explosive is measured. Most commonly used tests are

- 1 Ballistic mortar test
- 2 Cratering test

- 3 Underwater test
- 4 Plate dent test
- 5 Traulz lead block test
- 6 Cylinder compression test

These tests are very briefly explained hereunder.

### **21.3.1 Ballistic mortar test**

In this test a small charge of explosive is detonated in a chamber. The exhaust of the chamber is used for oscillation of a pendulum. The angle in which the pendulum oscillates depends upon the energy released by the detonation as also the weight and location of center of gravity of the pendulum. The explosive energy can be calculated from known values of the weight of the pendulum and its CG (Center of Gravity) position and measured value of angle of oscillation.

### **21.3.2 Cratering test**

The depth of a crater formed in a rock mass by the detonation of an explosive placed at its surface is related to the energy released by the detonation. Based on this principle, an explosive of specific weight is detonated on the surface of the rock to measure the critical and optimum depth of the crater. Critical depth is the maximum depth at which an explosive can be placed in the rock and yet a crater is formed. Optimum depth is the maximum depth at which an explosive can be placed in the rock and maximum volume of crater is achieved. These depths and the dimensions of crater formed are then used to get the strength of explosive.

### **21.3.3 Underwater test**

In this test a specific mass of explosive is detonated in a large pond filled with clear water. The explosive, while it is being detonated, is placed at sufficiently great depth of the water so that air bubbles do not form and escape to the surface of water. Upon such detonation a pressure wave is generated and travels spherically in all directions. The pressure of this wave is measured at a suitable distance.

From a score of tests carried out, equations have been developed to find the energy output of the explosion.

This test gives more accurate results than most other tests.

### **21.3.4 Plate dent test**

In this test a specific weight of explosive charge is kept on the top of a plate and detonated. Diameter, depth and volume of the dent caused by the detonation of explosive is measured and is then correlated with the strength of the explosive. In the case of low strength explosives, or where a very small quantity of explosive is to be used, an aluminum plate is used instead of the usual steel plate.

### 21.3.5 Traulz lead block test

The Traulz lead block test has been commonly used for measuring the strength of explosives for more than a century. The set-up for this test is shown in Figure 21.3.

In actual tests a cylindrical lead block having a diameter and length of 200 mm, as shown in the figure, is taken and a hole of diameter 25 mm is drilled in its center to a depth of about 125 mm. The weight of the explosive to be used for the test is 10 g. The explosive is wrapped in an aluminum foil and is placed centrally in the hole. After filling the remaining space with sand the explosive is detonated electrically.

Detonation causes the volume of the cavity to increase. The increase in volume is arrived at after deducting the original volume of the cavity and the volume of explosive from the newly measured volume. The result is expressed in  $\text{cm}^3$  and is called the Traulz number of the explosive.

In the case of explosives that yield a huge quantity of gases or those which have a high shattering effect, the lead block cracks and gives incorrect readings. In such cases an aluminum block is used.

Traulz numbers for some of the explosives are given in column 2 of the Table 21.1.

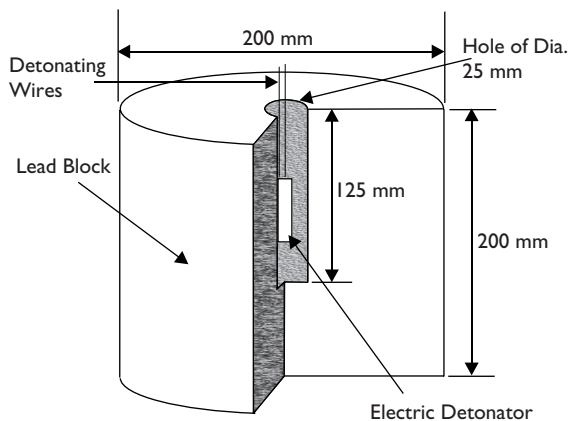

Figure 21.3 Traulz lead block test.

Table 21.1 Relative strength measured by lead block test.

Explosive	Gas volume in cc	Relative strength
Blasting Gelatine (8% Collodion Cotton)	520	100
Gun Cotton (13% N)	420	81
Ammonal	400	77
Gelatine Dynamite	400	77
Tetryl	350	67
Dynamite No. I	325	63
Picric Acid	290	56
Trinitrotoluene	260	50
Collodion Cotton (12% N)	250	48
Mercury Fulminate	150	29
Ammonium Nitrate	130	25

### 21.3.6 Cylinder compression test

This test is meant to measure relative strength.

In the cylinder compression test a solid lead cylinder of diameter 40 mm and height 60 mm is placed upon a rigid steel plate. On the top of this a steel plate of 4 mm thickness and 40 mm diameter is placed. Explosive of weight 100 g, contained in a shell of 40 mm diameter, is placed on the top of this steel plate. All this set up is shown in Figure 21.4.

Reduction  $\Delta H$  in the height of lead cylinder after detonation is measured in mm.

If  $\Delta H_R$  is the distance measured in the cylinder compression test for the reference explosive, and if  $\Delta H_t$  is the distance measured for the explosive being tested, the relative strength of the explosive under test is  $\Delta H_t/\Delta H_R$

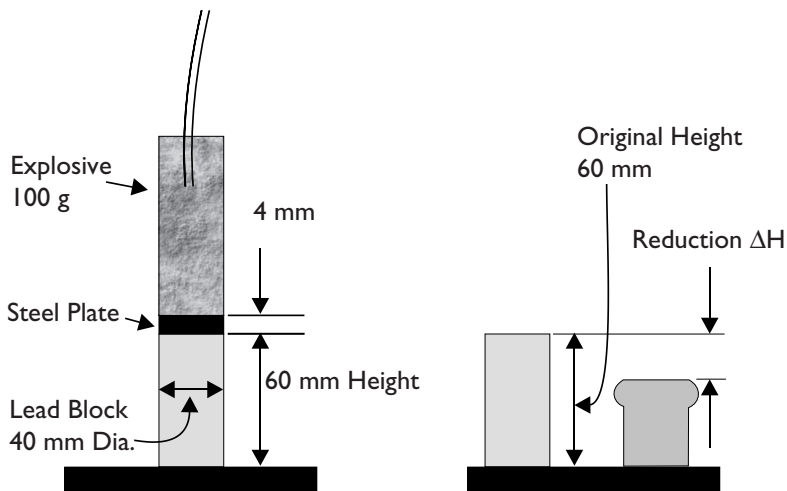

Figure 21.4 Cylinder compression test.

Table 21.2 Relative strength of some explosives measured by cylinder compression test.

Explosive	Relative strength
Explosive Gelatine (Made by Vogue's Process)	106.17
Hellhoffite	106.17
Nitroglycerin (Made by the Old Process)	100
Noble's Smokeless Powder	92.38
Gun Cotton (Made as per procedure used in 1889)	83.12
Dynamite	81.31
Amide Powder	69.87
Silver Fulminate	50.27
Mercury Fulminate	49.91
Mortar Powder	23.13

The relative strength of some explosives on the basis of cylinder compression is given in [Table 21.2](#).

Explosive strength can also be calculated from some other easily measurable parameters. The equations proposed for this purpose are empirical in nature. Some equations are given here below.

## 21.4 TESTS FOR MEASUREMENT OF SENSITIVITY

Safety is the most important aspect in the context of explosives. Many tests are carried out on the explosives to ascertain their safety from the viewpoint of different properties mentioned earlier. Some of the tests are:

- 1 Shock sensitivity test
- 2 Heat resistance test
- 3 Cap sensitivity test
- 4 Gap sensitivity test
- 5 Friction sensitivity test
- 6 Electrostatic discharge sensitivity test

Some details of these tests are presented in the following subsections.

### 21.4.1 Shock sensitivity test

This test measures the shock sensitivity of an explosive. Shock sensitivity is the reciprocal of impact resistance of an explosive. In actual tests a weight of either 2 kg or 5 kg is freely dropped on a sample of explosive weighing 100 mg placed on an anvil. Initially the drop height is kept at 10 mm. If the explosive does not explode by the impact, the drop height is increased by ten mm. The sequence is repeated and the height of the drop at which the explosive explodes is noted.

Different explosives give different heights of drop. These are indicators of their impact resistance.

The set up of the drop weight test is shown in [Figure 21.5](#).

The impact resistance of some explosives measured with 2 kg weight are given in [Table 21.3](#).

### 21.4.2 Heat resistance test

This test is carried out to investigate the mode of behavior of an explosive subjected to a gradually increasing thermal environment.

In actual tests a sample of an explosive is subjected to a temperature of the surrounding air slowly increasing at the rate of 3.3°C per hour until a reaction occurs. Time elapsed and temperature of the surroundings is continuously recorded. What type of reaction takes place is also noted. In cases where the explosive explodes, whether any fragmentation of material has taken place, or whether a crater has formed and what the dimensions of the crater are etc., are noted.





Figure 21.5 Drop weight test for measuring shock sensitivity.

Table 21.3 Impact resistance measured with 2 kg weight.

<i>Explosive</i>	<i>Falling distance in cm</i>
Mercury Fulminate	2
Nitroglycerin	4
Nitrocellulose (Dry)	5 to 10
Dynamite (25% kieselguhr)	7
Blasting Gelatine (7% Collodion Cotton)	12
Picric Acid	25
Trinitrotoluene	47 to 90
Black Powder	70
Dinitrobenzene	200

To reduce the time required for the test a sample is preheated to about 55°C below the previously known reaction temperature of the explosive.

### **21.4.3 Cap sensitivity test**

This test is used to determine susceptibility of explosives to detonation from the energy delivered by an electric blasting cap.

The most commonly used blasting cap is no. 8, which comprises 1600 mg of mercury fulminate and 400 mg of potassium chlorate.

In the actual test about 1 L of explosive is placed in a cardboard tube. In the case of slurry explosives or emulsions a polypropylene bottle is used. The tube or cartridge is placed on the top of a witness plate made of steel. The detonator (blasting cap no. 8) is inserted in the explosive sample and detonated. If detonation of the sample explosive takes place, the witness plate is torn or penetrated. This can conclusively prove if the sample explosive is cap sensitive or not.

The sample explosive is considered a high explosive if it fails the No. 8 cap test and a low explosive if it passes.

### **21.4.4 Gap sensitivity test**

This test is used to find the minimum distance required to prevent sympathetic detonation i.e. the detonation of a test explosive by the shock wave generated by a donor explosive.

There are many versions of the test. Only the simplest among them is described below.

A cartridge of explosive of length 200 mm is divided into two by a cut in the middle. One of these parts is used as a donor and other is a receptor. A no. 6 detonator is inserted in the donor. The receptor is kept in the same line as the donor at a certain gap distance and the donor is detonated. If the receptor also detonates by the shock, the test is repeated with a larger gap and the maximum gap at which the receptor detonates is determined.

In cases where the test is to be carried out in confined conditions, the explosive cartridge parts are inserted in a steel tube having a thickness of 6 mm and internal diameter 5 to 6 mm more than the diameter of the cartridge. The length of the tube must be at least 200 mm more than the total length of the two cartridges including the gap kept between the cartridges. To mimic field conditions the space in the tube at the end of donor and receptor explosive is filled with wetted sticky earth and the gap between the cartridge and tube is filled with sand. Here also the test is repeated to find out the maximum distance over which the receptor cartridge detonates by the detonation of the donor cartridge.

In the case of a few explosives for a certain gap distance, the receptor does not detonate but deflagrates. Noting such distance from the observations in the test is also important.

### **21.4.5 Friction sensitivity test**

Two versions of tests for friction sensitivity of an explosive are recognized.

In the first version, called the ABL Friction Test, a sample of explosive is placed on a sliding anvil. The rotating wheel on top of the anvil exerts a well-defined normal

force on the explosive in a vertical direction. The anvil is made to move at different speeds in a horizontal direction. Instances of deflagration or detonation are noted after each slide of the anvil. Analysis of the observation gives the friction sensitivity of the explosive.

In the second version, called the BAM Friction Test, a sample of the explosive is placed on a porcelain disk. A pin with a spherical shaped end exerts pressure on the explosive. The pressure can be varied by adjusting the weight kept on the lever arm. An electric motor attached to the plate moves the plate to and fro. This generates friction and the explosive sample either deflagrates or detonates. Analysis of the observation gives the friction sensitivity of the explosive.

#### **21.4.6 Electrostatic discharge sensitivity test**

This test is meant to determine the response of an explosive when subjected to various levels of electrostatic discharge energy.

A capacitor with known electric voltage (usually 5000 V) stored in it is connected to a needle. The sample of explosive is placed on the top of a conductor plate. The needle is then moved towards the explosive sample. At a certain distance between the explosive and the needle the explosive deflagrates or detonates. Analysis of the observations in the test gives the electrostatic discharge sensitivity of the explosive.

### **21.5 TESTS RELATED TO STORAGE OF EXPLOSIVE**

The various types of sensitivities discussed above are very important from the viewpoint of the handling of the explosives. In many instances explosives have to be stored for long periods of time. Certain properties of the explosives become very crucial in such conditions. Tests related to these are covered in the following subsections.

#### **21.5.1 Effect of wetness test**

In this test a 5 g sample of the explosive is kept in surrounding air having a certain degree of humidity for a period of one hour. Any reaction such as degradation, deflagration or detonation that takes place during such storage is noted. The air in the container of the sample is also tested to measure the gases evolved during the period.

The test is repeated with higher humidity and higher sample weight.

If the explosive does not ignite spontaneously or does not release more than 1 L of inflammable or toxic gas per kg weight of the explosive it is not considered as dangerous when wet.

#### **21.5.2 Internal ignition test**

The objective of this test is to find out the response of an explosive to rapidly rising temperature and pressure. These conditions are experienced in adjoining fires or stormy weather.

The sample, with an initial temperature of 25°C, is loaded into a schedule 80 pipe with forged steel end caps. A black powder bag igniter is inserted into the center of the pipe and the leads are sealed with epoxy resin. The igniter is fired and the results

are assessed. Either the pipe or at least one of the end caps must be fragmented into at least two distinct pieces for a positive result.

The test is considered negative (the material passes) if the pipe is merely split open or the caps are blown off in one piece. Three trials are performed unless a positive result occurs earlier. The test determines if a material will explode or detonate when ignited under confinement.

### **21.5.3 Material compatibility test**

This test is performed to determine the ability of a material to coexist in intimate contact with an explosive without adverse reaction, for a certain acceptable period of time. This test measures heat increase or heat loss. It is used when looking for an exothermic or endothermic reaction. This test may be also used for composite explosives.

### **21.5.4 Vacuum stability test**

When explosives are to be transported through, or are to be stored in, a very low pressure region, this test becomes important because in such an atmosphere apart from the container, the explosive must also be stable.

In this test a sample of explosive is placed in surroundings with air pressure of 5 mm Hg for 48 hrs at constant temperature. The volume of gas liberated during this period is calculated after measurement of pressure.

If the ingredients of a mixture of explosive are separately tested and then the explosive made by the same weight of each ingredient in a mixture form is tested, and if the gas volume evolved from the mixture is more than the sum of gas volume evolved individually, it means that the ingredients are reacting with each other at a certain rate.

## **21.6 MISCELLANEOUS TESTS**

In the manufacture and use of explosive or other activities closely connected with explosives, failures of the explosives or related disasters can happen. To avoid such occurrences many other tests are performed with the objective of evaluating a specific property of an explosive. Important amongst them are those described below. Some of these are very similar to those described in earlier sections.

### **21.6.1 Critical diameter test**

This test is conducted to measure the minimum diameter of an explosive column that can satisfactorily propagate an explosive detonation.

The test uses black seamless steel tubes of schedule 40, class B, type A-53 variety of several different diameters and lengths. The length of the tube is kept at about 3 times the diameter. Explosive filled in the pipe is detonated at one end. A witness plate placed at the other end indicates if the detonation has propagated to the other end. Alternatively, such verification can also be done by velocity probe. If detonation travels to the other end in three of the five tests for the same diameter pipe, the test is

repeated with a smaller diameter pipe. When detonation does not travel to the other end in three consecutive tests the critical diameter is considered to be the internal diameter of that pipe plus 5 mm.

### 21.6.2 Critical height test

The purpose of this test is to determine the height of explosive in a metal tube at which the burning reaction of an explosive changes to detonation.

The test also uses black seamless steel tubes of schedule 40, class B, type A-53 variety of several different diameters and lengths. The pipe is held in a vertical position and filled with explosive. A 12 gram igniter is kept at the bottom of the explosive column with wires connected to it for initiating the burning reaction. After closing the bottom of the pipe with a threaded cap, the burning is initiated. One of several devices is used to find out the velocity of propagation of the reaction in the explosive. A sudden increase in the velocity of propagation indicates that the burning reaction has transformed to detonation. The height at which such transformation has taken place is treated as the critical height. By repeating the test three times the height reading is reconfirmed.

Observations are made by using pipes of different diameters. A plot of internal diameter of the pipes and the critical height for that internal diameter can be used to find the critical height for other diameters.

### 21.6.3 Bullet impact test

The impact of a bullet is a means of transfer of energy to an explosive. The consequent reaction can be none, deflagration or detonation depending upon the type of explosive and the energy transferred by the impact.

In the actual test a 0.3 caliber (7.62 mm diameter) bullet is fired at an explosive mass from a distance of 30 yards (27.431 m). The firing device used in the test is a rapid action gun like an AK 47 capable of firing at the rate of 600 rounds/min at a speed of 856 m/s. Three rounds are fired at the explosive in three different orientations so the penetration of the bullets is in the most sensitive locations of the explosive mass. A post-test inspection of the test film and hardware is performed to evaluate the reaction.

If the explosive does not detonate it is given a good rating; if no reaction takes place it is excellent.

### 21.6.4 Koenen test

This test is used to determine the sensitiveness of a material to the effect of intense heat under vented confinement. In this test, the material is placed in a steel container with an orifice plate. The test apparatus is then placed in a protective steel box, and heated at a specified rate. A series of trials is conducted using different sizes of orifices. A "go" reaction is determined by examining the container. Conducting three successive "no-go" reactions with an orifice plate size above that which produced a positive result concludes the test. This orifice is called the limiting diameter. The limiting diameter may be used to evaluate the degree of venting required to avoid an explosion in the process.